

Corporate and Business Law (ENG) (F4) September 2017 to August 2018

This syllabus and study guide is designed to help with planning study and to provide detailed information on what could be assessed in any examination session.

THE STRUCTURE OF THE SYLLABUS AND STUDY GUIDE

Relational diagram of paper with other papers

This diagram shows direct and indirect links between this paper and other papers preceding or following it. Some papers are directly underpinned by other papers such as Advanced Performance Management by Performance Management. These links are shown as solid line arrows. Other papers only have indirect relationships with each other such as links existing between the accounting and auditing papers. The links between these are shown as dotted line arrows. This diagram indicates where you are expected to have underpinning knowledge and where it would be useful to review previous learning before undertaking study.

Overall aim of the syllabus

This explains briefly the overall objective of the paper and indicates in the broadest sense the capabilities to be developed within the paper.

Main capabilities

This paper's aim is broken down into several main capabilities which divide the syllabus and study guide into discrete sections.

Relational diagram of the main capabilities

This diagram illustrates the flows and links between the main capabilities (sections) of the syllabus and should be used as an aid to planning teaching and learning in a structured way.

Syllabus rationale

This is a narrative explaining how the syllabus is structured and how the main capabilities are linked. The rationale also explains in further detail what the examination intends to assess and why.

Detailed syllabus

This shows the breakdown of the main capabilities (sections) of the syllabus into subject areas. This is the blueprint for the detailed study guide.

Approach to examining the syllabus

This section briefly explains the structure of the examination and how it is assessed.

Study Guide

This is the main document that students, learning and content providers should use as the basis of their studies, instruction and materials. Examinations will be based on the detail of the study guide which comprehensively identifies what could be assessed in any examination session. The study guide is a precise reflection and breakdown of the syllabus. It is divided into sections based on the main capabilities identified in the syllabus. These sections are divided into subject areas which relate to the sub-capabilities included in the detailed syllabus. Subject areas are broken down into sub-headings which describe the detailed outcomes that could be assessed in examinations. These outcomes are described using verbs indicating what exams may require students to demonstrate, and the broad intellectual level at which these may need to be demonstrated (*see intellectual levels below).

INTELLECTUAL LEVELS

The syllabus is designed to progressively broaden and deepen the knowledge, skills and professional values demonstrated by the student on their way through the qualification.

The specific capabilities within the detailed syllabuses and study guides are assessed at one of three intellectual or cognitive levels:

Level 1: Knowledge and comprehension

Level 2: Application and analysis
Level 3: Synthesis and evaluation

Very broadly, these intellectual levels relate to the three cognitive levels at which the Knowledge module, the Skills module and the Professional level are assessed.

Each subject area in the detailed study guide included in this document is given a 1, 2, or 3 superscript, denoting intellectual level, marked at the end of each relevant line. This gives an indication of the intellectual depth at which an area could be assessed within the examination. However, while level 1 broadly equates with the Knowledge module, level 2 equates to the Skills module and level 3 to the Professional level, some lower level skills can continue to be assessed as the student progresses through each module and level. This reflects that at each stage of study there will be a requirement to broaden, as well as deepen capabilities. It is also possible that occasionally some higher level capabilities may be assessed at lower levels.

LEARNING HOURS AND EDUCATION RECOGNITION

The ACCA qualification does not prescribe or recommend any particular number of learning hours for examinations because study and learning patterns and styles vary greatly between people and organisations. This also recognises the wide diversity of personal, professional and educational circumstances in which ACCA students find themselves.

As a member of the International Federation of Accountants, ACCA seeks to enhance the education recognition of its qualification on both national and international education frameworks, and with educational authorities and partners globally. In doing so, ACCA aims to ensure that its qualifications are recognized and valued by governments, regulatory authorities and employers across all sectors. To this end, ACCA qualifications are currently recognized on the education frameworks in several countries. Please refer to your national education framework regulator for further information.

Each syllabus contains between 23 and 35 main subject area headings depending on the nature of

the subject and how these areas have been broken down.

GUIDE TO EXAM STRUCTURE

The structure of examinations varies within and between modules and levels.

The Fundamentals level examinations contain 100% compulsory questions to encourage candidates to study across the breadth of each syllabus.

The Knowledge module is assessed by equivalent two-hour paper based and computer based examinations.

The Skills module examinations F5-F9 are all paper based three-hour papers containing a mix of objective and longer type questions. The *Corporate and Business Law* (F4) paper is a two-hour computer based objective test examination which is also available as a paper based version from the December 2014 examination session.

The Professional level papers are all three-hour paper based examinations, all containing two sections. Section A is compulsory, but there will be some choice offered in Section B.

For all three hour examination papers, ACCA has introduced 15 minutes reading and planning time.

This additional time is allowed at the beginning of each three-hour examination to allow candidates to read the questions and to begin planning their answers before they start writing in their answer books. This time should be used to ensure that all the information and exam requirements are properly read and understood.

During reading and planning time candidates may only annotate their question paper. They may not write anything in their answer booklets until told to do so by the invigilator.

The Essentials module papers all have a Section A containing a major case study question with all requirements totalling 50 marks relating to this case. Section B gives students a choice of two from three 25 mark questions.

Section A of both the P4 and P5 Options papers contain one 50 mark compulsory question, and Section B will offer a choice of two from three questions each worth 25 marks each.

Section A of each of the P6 and P7 Options papers contains 60 compulsory marks from two questions; question 1 attracting 35 marks, and question 2 attracting 25 marks. Section B of both these Options papers will offer a choice of two from three questions, with each question attracting 20 marks.

All Professional level exams contain four professional marks.

The pass mark for all ACCA Qualification examination papers is 50%.

GUIDE TO EXAMINATION ASSESSMENT

ACCA reserves the right to examine anything contained within the study guide at any examination session. This includes knowledge, techniques, principles, theories, and concepts as specified.

For the financial accounting, audit and assurance, law and tax papers except where indicated otherwise, ACCA will publish *examinable documents* once a year to indicate exactly what regulations and legislation could potentially be assessed within identified examination sessions..

For paper based examinations regulation *issued* or legislation *passed* on or before 31st August annually, will be examinable from 1st September of the following year to 31st August of the year after that. Please refer to the examinable documents for the paper (where relevant) for further information.

Regulation issued or legislation passed in accordance with the above dates may be examinable even if the *effective* date is in the future.

The term issued or passed relates to when regulation or legislation has been formally approved.

The term effective relates to when regulation or legislation must be applied to an entity transactions and business practices.

The study guide offers more detailed guidance on the depth and level at which the examinable documents will be examined. The study guide should therefore be read in conjunction with the examinable documents list.

Syllabus

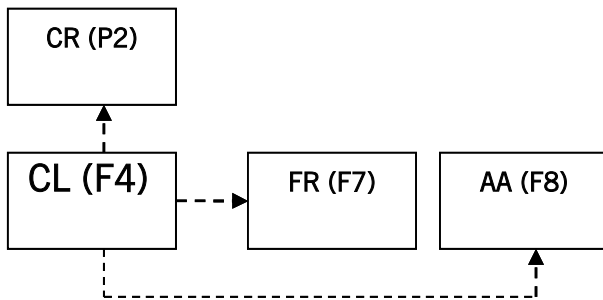

AIM

To develop knowledge and skills in the understanding of the general legal framework, and of specific legal areas relating to business, recognising the need to seek further specialist legal advice where necessary.

MAIN CAPABILITIES

On successful completion of this paper candidates should be able to:

- A** Identify the essential elements of the legal system, including the main sources of law
- B** Recognise and apply the appropriate legal rules relating to the law of obligations
- C** Explain and apply the law relating to employment relationships
- D** Distinguish between alternative forms and constitutions of business organisations
- E** Recognise and compare types of capital and the financing of companies
- F** Describe and explain how companies are managed, administered and regulated
- G** Recognise the legal implications relating to insolvency law
- H** Demonstrate an understanding of corporate fraudulent and criminal behaviour.

RELATIONAL DIAGRAM OF MAIN CAPABILITIES

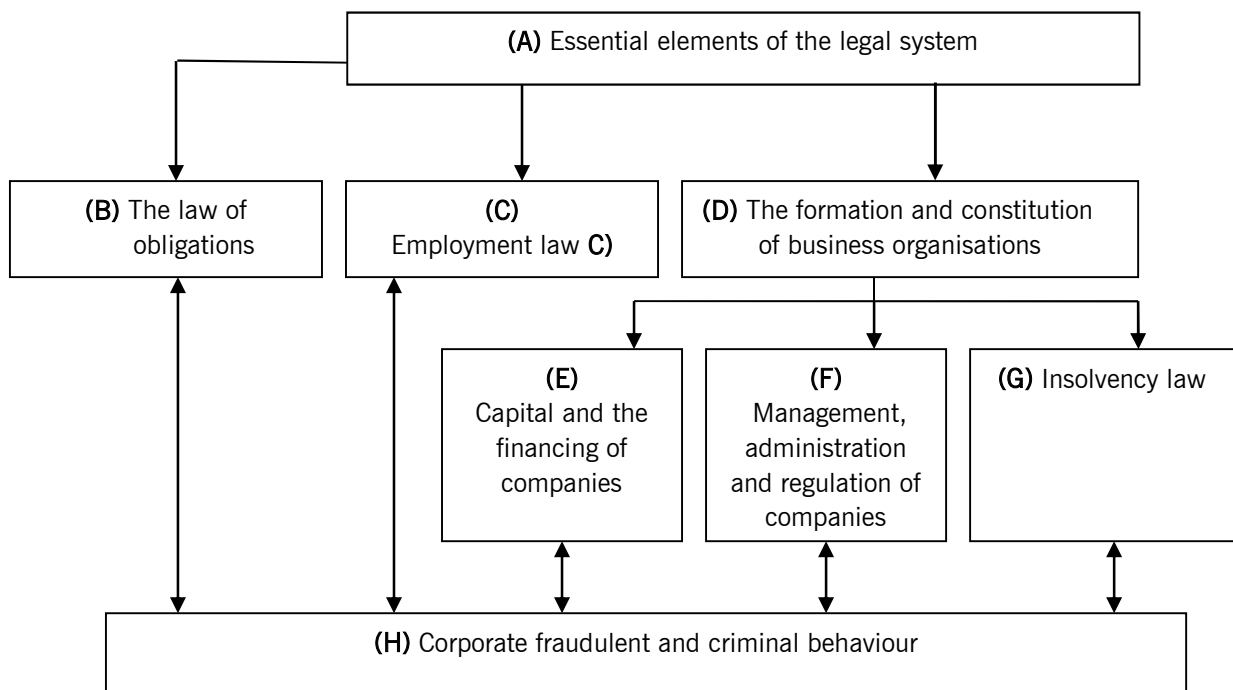

RATIONALE

Corporate and Business Law is divided into eight areas. The syllabus starts with an introduction to the overall English legal system such as the court system and sources of law. It then leads into the area of the law of obligations including contract and tort, which underpin business transactions generally.

The syllabus then covers a range of specific legal areas relating to various aspects of business of most concern to finance professionals. These are the law relating to employment and the law relating to companies. These laws include the formation and constitution of companies, the financing of companies and types of capital, and the day-to-day management, the administration and regulation of companies and legal aspects of insolvency law.

The final section links back to all the previous areas. This section deals with corporate fraudulent and criminal behaviour.

DETAILED SYLLABUS

A Essential elements of the legal system

1. Law and the legal system
2. Sources of law

B The law of obligations

1. Formation of contract
2. Content of contracts
3. Breach of contract and remedies
4. The law of torts and professional negligence

C Employment law

1. Contract of employment
2. Dismissal and redundancy

D The formation and constitution of business organisations

1. Agency law

2. Partnerships
3. Corporations and legal personality
4. The formation and constitution of a company

E Capital and the financing of companies

1. Share capital
2. Loan capital
3. Capital maintenance and dividend law

F Management, administration and the regulation of companies

1. Company directors
2. Other company officers
3. Company meetings and resolutions

G Insolvency law

1. Insolvency and administration

H Corporate fraudulent and criminal behaviour

1. Fraudulent and criminal behaviour

APPROACH TO EXAMINING THE SYLLABUS

The syllabus is assessed by a two-hour paper-based examination.

The examination consists of:

Section A

- 25 x 2 mark objective test questions 50%
- o 20 x 1 mark objective test questions 20%

-

Section B

- 5 x 6 mark multi-task question 30%
- 100%.

All questions are compulsory.

NOTE ON CASE LAW

Candidates should support their answers on the paper-based multi-task questions with analysis referring to cases or examples. There is no need to detail the facts of the case. Remember, it is the point of law that the case establishes that is important, although knowing the facts of cases can be helpful as sometimes questions include scenarios based on well-known cases. Further it is not necessary to quote section numbers of Acts.

Study Guide

A ESSENTIAL ELEMENTS OF THE LEGAL SYSTEM

1. Law and the legal system

- a) Define law and distinguish types of law.^[1]
- b) Explain the structure and operation of the courts.^[1]

2. Sources of law

- a) Explain what is meant by case law and precedent.^[1]
- b) Explain legislation and evaluate delegated legislation.^[1]
- c) Illustrate the rules and presumptions used by the courts in interpreting statutes.^[1]
- d) Identify the concept and impact of human rights law.^[1]

B THE LAW OF OBLIGATIONS

1. Formation of contract

- a) Analyse the nature of a simple contract.^[2]
- b) Explain the meaning of an offer and distinguish it from an invitation to treat.^[2]
- c) Explain the termination of an offer. (2)
- d) Explain the meaning and consequence of acceptance.^[2]
- e) Explain the need for consideration.^[2]
- f) Explain adequacy and sufficiency of consideration.^[2]
- g) Analyse the doctrine of privity.^[2]
- h) Distinguish the presumptions relating to intention to create legal relations.^[2]

2. Content of contracts

- a) Distinguish terms from mere representations.^[1]
- b) Define the various contractual terms.^[1]
- c) Explain the control over terms in consumer contracts and the operation of exclusion clauses in non-consumer contracts.^[2]

3. Breach of contract and remedies

- a) Explain the ways in which a contract may be discharged. (2)
- b) Explain the meaning and effect of breach of contract, and the remedies available in common law.^[2]
- c) Explain the rules relating to the award of damages.^[2]
- d) Analyse the equitable remedies for breach of contract.^[2]

4. The law of torts and professional negligence

- a) Explain the meaning of tort.^[2]
- b) Explain the tort of 'passing off.' ^[2]
- c) Explain the tort of negligence including the duty of care and its breach, and the concept of vicarious liability.^[2]
- d) Explain the meaning of causality and remoteness of damage.^[2]
- e) Discuss defences to actions in negligence.^[2]
- f) Explain and analyse the duty of care of accountants and auditors. ^[2]

C EMPLOYMENT LAW

1. Contract of employment

- a) Distinguish between employees and the self-employed.^[2]
- b) Explain the nature of the contract of employment and common law and statutory duties placed on the employer and employee.^[2]

2. Dismissal and redundancy

- a) Explain termination of employment by notice.^[2]
- b) Distinguish between summary and constructive dismissal.^[2]
- c) Explain wrongful dismissal.^[2]
- d) Explain unfair dismissal, including the procedure, and fair and unfair reasons for dismissal.^[2]
- e) Discuss the remedies available to those who have been subject to unfair dismissal.^[2]
- f) Explain what is meant by redundancy and the operation of the rules relating to it.^[2]

D THE FORMATION AND CONSTITUTION OF BUSINESS ORGANISATIONS

1. Agency law

- a) Define the role of the agent and give examples of such relationships paying particular regard to partners and company directors.^[2]
- b) Explain the formation of the agency relationship.^[2]
- c) Define the authority of the agent.^[2]
- d) Explain the potential liability of both principal and agent.^[2]

2. Partnerships

- a) Demonstrate a knowledge of the legislation governing the partnership, both unlimited and limited.^[1]
- b) Discuss the formation of a partnership.^[2]
- c) Explain the authority of partners in relation to partnership activity.^[2]
- d) Analyse the liability of various partners for partnership debts.^[2]
- e) Explain the termination of a partnership, and partners' subsequent rights and liabilities.^[2]

3. Corporations and legal personality

- a) Distinguish between sole traders, partnerships and companies.^[1]
- b) Explain the meaning and effect of limited liability.^[2]
- c) Analyse different types of companies, especially private and public companies.^[2]
- d) Illustrate the effect of separate personality and the veil of incorporation.^[2]
- e) Recognise instances where separate personality will be ignored (lifting the veil of incorporation).^[2]

4. The formation and constitution of a company

- a) Explain the role and duties of company promoters, and the breach of those duties and remedies available to the company.^[2]
- b) Explain the meaning of, and the rules relating to, pre-incorporation contracts.^[2]
- c) Describe the procedure for registering companies, both public and private, including the system of streamlined company registration.^[1]
- d) Describe the statutory books, records and returns, including the confirmation statement and the register of people with significant control, that companies must keep or make.^[1]
- e) Analyse the effect of a company's constitutional documents.^[2]
- f) Describe the contents of model articles of association.^[1]
- g) Explain how articles of association can be changed.^[2]
- h) Explain the controls over the names that companies may or may not use.^[2]

E CAPITAL AND THE FINANCING OF COMPANIES

1. Share capital

- a) Examine the different types of capital.^[2]
- b) Illustrate the difference between various classes of shares, including treasury shares, and the procedure for altering class rights.^[2]
- c) Explain allotment of shares, and distinguish between rights issue and bonus issue of shares.^[2]
- d) Examine the effect of issuing shares at either a discount, or at a premium.^[2]

2. Loan capital

- a) Define companies' borrowing powers.^[1]
- b) Explain the meaning of loan capital and debenture.^[2]
- c) Distinguish loan capital from share capital, and explain the different rights held by shareholders and debenture holders.^[2]
- d) Explain the concept of a company charge and distinguish between fixed and floating charges.^[2]
- e) Describe the need and the procedure for registering company charges.^[2]

3. Capital maintenance and dividend law

- a) Explain the doctrine of capital maintenance and capital reduction.^[2]
- b) Explain the rules governing the distribution of dividends in both private and public companies.^[2]

F MANAGEMENT, ADMINISTRATION AND THE REGULATION OF COMPANIES

1. Company directors

- a) Explain the role of directors in the operation of a company, and the different types of directors, such as executive/ non-executive directors or

de jure and *de facto* directors, and shadow directors.^[2]

- b) Discuss the ways in which directors are appointed, can lose their office and the disqualification of directors.^[2]
- c) Distinguish between the powers of the board of directors, the managing director/ chief executive and individual directors to bind their company.^[2]
- d) Explain the duties that directors owe to their companies, and the controls imposed by statute over dealings between directors and their companies, including loans.^[2]

2. Other company officers

- a) Discuss the appointment procedure relating to, and the duties and powers of, a company secretary.^[2]
- b) Discuss the appointment procedure relating to, and the duties and rights of a company auditor, and their subsequent removal or resignation.^[2]

3. Company meetings and resolutions

- a) Distinguish between types of meetings: general meetings and annual general meetings.^[1]
- b) Distinguish between types of resolutions: ordinary, special, and written.^[2]
- c) Explain the procedure for calling and conducting company meetings.^[2]

G INSOLVENCY LAW

1. Insolvency and administration

- a) Explain the meaning of and procedure involved in voluntary liquidation, including members' and creditors' voluntary liquidation.^[2]
- b) Explain the meaning of, the grounds for, and the procedure involved in compulsory liquidation.^[2]

- c) Explain the order in which company debts will be paid off on liquidation.^[2]
- d) Explain administration as a general alternative to liquidation.^[2]
- e) Explain the way in which of an administrator may be appointed, the effects of such appointment, and the powers and duties an administrator.^[2]

H CORPORATE FRAUDULENT AND CRIMINAL BEHAVIOUR

1. Fraudulent and criminal behaviour

- a) Recognise the nature and legal control over insider dealing.^[2]
- b) Recognise the nature and legal control over market abuse.^[2]
- c) Recognise the nature and legal control over money laundering.^[2]
- d) Recognise the nature and legal control over bribery.^[2]
- e) Discuss potential criminal activity in the operation, management and liquidation of companies.^[2]
- f) Recognise the nature and legal control over fraudulent and wrongful trading.^[2]

SUMMARY OF CHANGES TO F4 ENG

ACCA periodically reviews its qualification syllabuses so that they fully meet the needs of stakeholders such as employers, students, regulatory and advisory bodies and learning providers.

The areas where there have been additions to the syllabus are shown in Table 1 below:

Table 1 – Additions to F4 ENG

Section and subject area	Syllabus content
B2c)	The control over terms in consumer contracts.

There have been no deletions from the syllabus.